

THE POWER OF

REDARC[®]

BCDCMB-011

Mounting Bracket for Selected
REDARC BCDC Battery Chargers

SUITABLE FOR TOYOTA LANDCRUISER 300 SERIES

(06/2021 - ONWARDS)

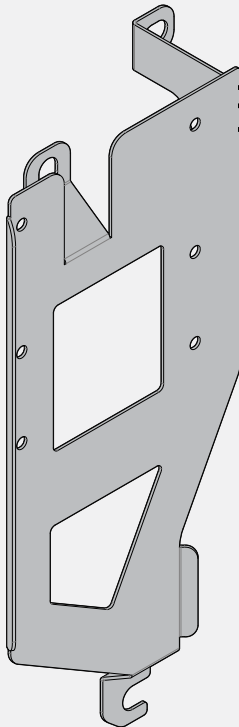

BCDC Mounting Bracket

Suitable for TOYOTA Landcruiser 300 Series

[06/2021 – ONWARDS]

The REDARC **BCDCMB-011** Mounting Bracket is designed to install your BCDC Classic Battery Charger* close to an auxiliary battery mounted in the engine bay. Do not use if the battery is located elsewhere.

For maximum performance, mount your BCDC Classic in the cool airflow at the front of your vehicle, away from high temperature areas.

The BCDC Mounting Bracket is constructed from durable stainless steel and has been designed to fit existing mounting points in your vehicle for ease of installation.

***NOTE:** The BCDC Mounting Brackets are only for engine bay designed Battery Chargers. DO NOT use the Mounting Bracket to install a BCDC Core Battery Charger (BCDCN1225, BCDCN1240).

WARNINGS AND SAFETY INFORMATION

SAVE THESE INSTRUCTIONS — this manual contains important safety instructions. Do not install the BCDC Mounting Bracket unless you have read and understood this manual.

REDARC recommends to review your vehicle to ensure this kit suits your vehicle's make and specifications.

REDARC recommends that the BCDC Mounting Brackets be installed by a suitably qualified person. It is the installers responsibility to ensure their installation complies with any applicable legal and regulatory requirements.

Disclaimer: REDARC accepts no liability for any injury, loss or property damage which may occur from the improper or unsafe installation or use of its products.

SAFETY MESSAGE CONVENTIONS

Safety messages in this manual include a signal word to indicate the level of the hazard as follows:

⚠ WARNING

Indicates a potentially hazardous situation which **could result in death or serious injury to the operator or to bystanders.**

⚠ CAUTION

Indicates a potentially hazardous situation which **may result in moderate or minor injury to the operator or to bystanders.**

NOTICE

Indicates a situation that **may cause equipment damage.**

⚠ WARNING

- Do not operate around the engine bay with the engine operating. Ensure the vehicle is OFF before mounting Battery Charger assembly.
- Installing the Mounting Bracket requires removal and refitment of the horn. Check the horn is properly connected and still functions before driving your vehicle.

⚠ CAUTION

- Use Personal Protective Equipment (PPE). Wear appropriate clothing as well as eye protection when operating power tools.
- Take care when working in and around engine bay to avoid punch points, sharp edges and hot surfaces.



NOTICE

- Removing existing vehicle fixings may expose bare metal, resulting in rust. Retouch any exposed metal with rust inhibitor if it is not an earth connection.
- Damage to cabling can cause failure of the Battery Charger and vehicle electrical systems. Ensure wiring is clear of sharp edges and moving parts.

BCDC MOUNTING BRACKET PARTS

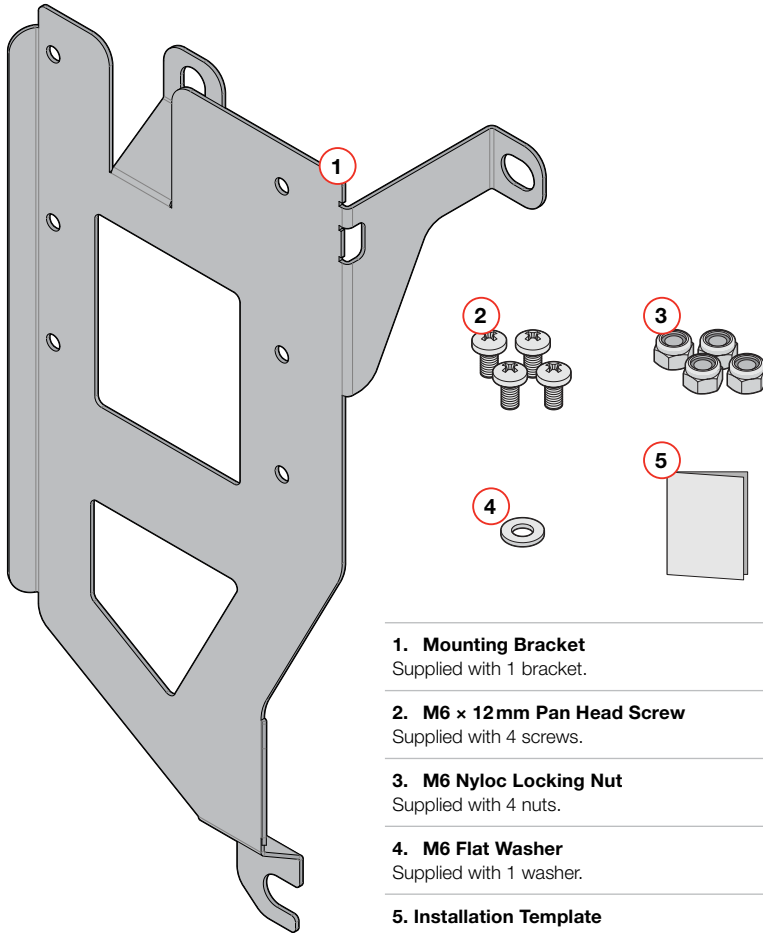

1. Mounting Bracket

Supplied with 1 bracket.

2. M6 x 12mm Pan Head Screw

Supplied with 4 screws.

3. M6 Nyloc Locking Nut

Supplied with 4 nuts.

4. M6 Flat Washer

Supplied with 1 washer.

5. Installation Template

RECOMMENDED TOOLS

The tools listed below are typically sufficient to complete the installation, however, some specific models may require more specialised tools.

- Metric Socket set (at least 10 mm and 12 mm socket) with extension bars.
- Metric Spanner 10mm, 12 mm and 13mm.
- Medium (#3) Phillips-Head Screwdriver.

ASSEMBLY

ASSEMBLING BATTERY CHARGER TO BRACKET

The BCDC Mounting Bracket must be fitted to the Battery Charger before mounting to the vehicle. Do not install the BCDC Mounting Bracket to the vehicle first.

Use the supplied M6 × 12mm Pan Head Bolts and M6 Nyloc Locking Nuts to secure the Battery Charger to the Mounting Bracket as demonstrated in [Figure 1](#).

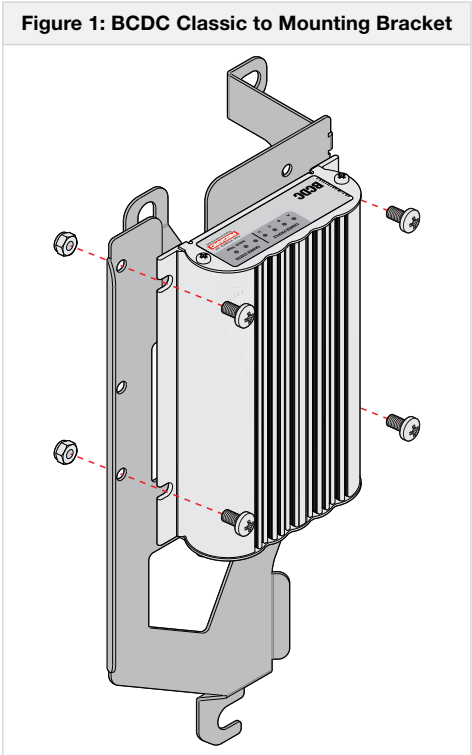

INSTALLATION LOCATION

The assembled Mounting Bracket and Battery Charger will be mounted on the left side of the radiator support panel in the engine bay.

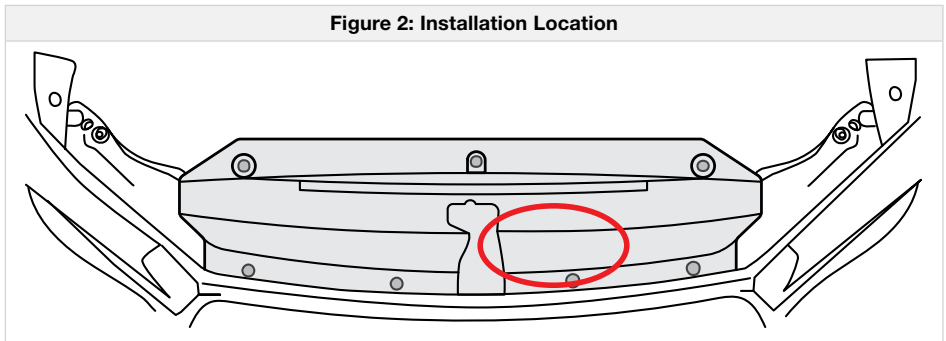

PRIOR TO INSTALLATION

REMOVING RADIATOR COVER PANEL

Remove the radiator cover panel by removing all push clips, refer to [Figure 3](#). To remove these, depress the centre of each clip and they will lift out.

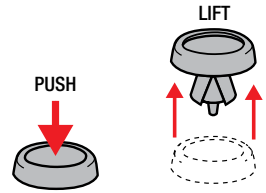
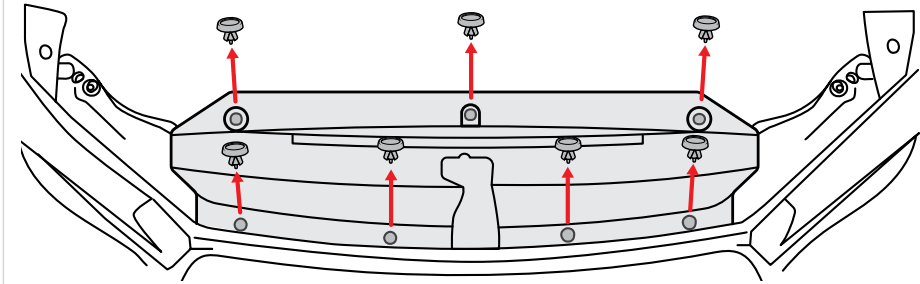

Figure 3: Removing Cover Panel



COMPLETE BATTERY CHARGER WIRING

NOTICE: Damage to cabling can cause failure to the Battery Charger and the vehicle's electrical system. Ensure wiring is clear of sharp edges, moving parts and has enough slack to allow for flexing.

Fit the Battery Charger with the wiring connected to the bracket before mounting in the vehicle. It is difficult to access the Battery Charger once the bracket is installed.

Complete the required wiring in accordance with your Battery Charger's instruction manual.

REMOVING VEHICLE FIXINGS

NOTICE: Removing existing vehicle fixings may expose bare metal, resulting in rust. Retouch any exposed metal with rust inhibitor if it is not an earth connection.

Remove the two vehicle fixings located in the radiator support panel and horn assembly; and loosen the lower vehicle fixing as indicated in **Figure 4**.

Retain the vehicle fixings and horn assembly.

Figure 4: Removing Vehicle Fixings

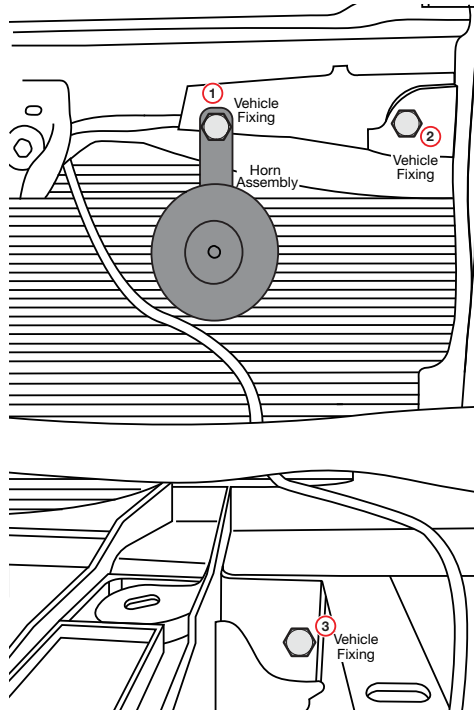

INSTALLATION

FITTING THE MOUNTING BRACKET TO THE VEHICLE

▲ WARNING: Installing the Mounting Bracket requires removal and refitment of the horn. Check the horn is properly connected and still functions before driving your vehicle.

To fit the Mounting Bracket assembly to the vehicle refer to [Figure 5](#) and adhere to the following steps:

1. Slide the lower mounting point into the loosened vehicle fixing **(1)**.
2. Align and loosely refit the horn assembly (refit the horn assembly facing rearwards) and the top left mounting point of the Mounting Bracket using the vehicle fixing **(2)**.
3. Align the top right mounting point to the vehicle fixing hole. Use the vehicle fixing and the supplied flat washer to loosely secure **(3)**.
4. Tighten all vehicle fixings to the vehicle manufacturers torque specifications.

Figure 5: Securing Mounting Bracket to Vehicle

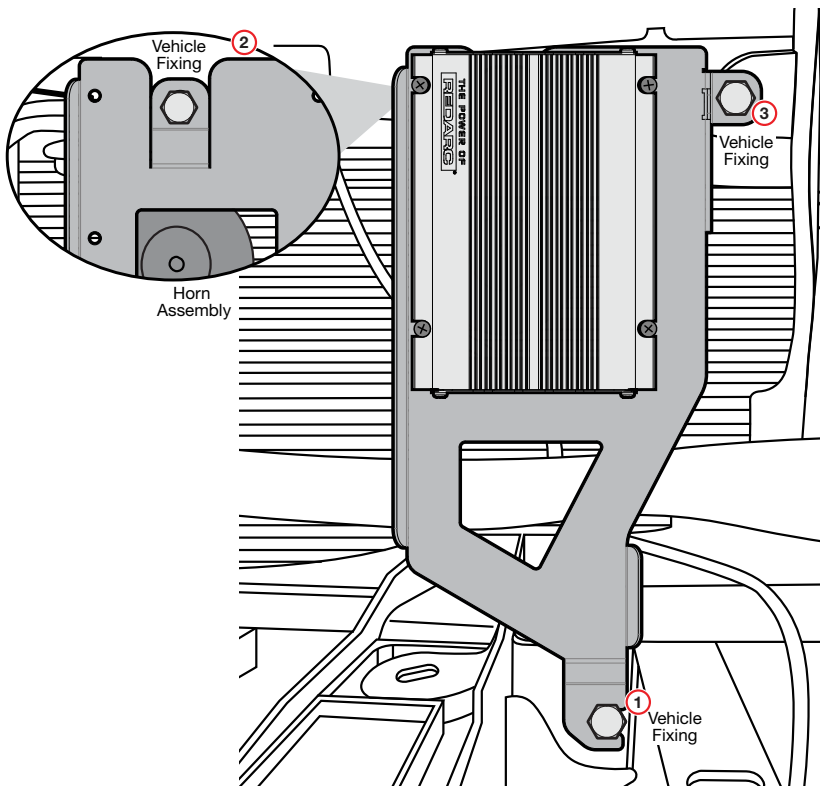

FINALISING INSTALLATION

CUTTING AN INSPECTION HOLE IN THE RADIATOR COVER PANEL

Before fitting the radiator cover panel back into the vehicle, use the supplied template to create an inspection hole to view the status of your Battery Charger. Following the instructions and marking on the provided template, and cut the inspection hole away from the vehicle.

1. Align the template as indicated on the radiator cover panel.
2. Mark the holes as indicated and cut neatly between the holes to create the inspection window of your Battery Charger. REDARC recommend using a centre punch/scribe to mark the holes and a small, serrated blade or reciprocating saw for cutting the trim. De-burr rough edges.

IMPORTANT: The supplied template is at a 1:1 scale. Altering this scale (e.g. photocopying) could result in the wrong size hole being cut in the radiator cover panel. Measure the printed scale/rule guide on the template sheet to confirm that the scale is correct before modifying the radiator cover panel.

⚠ CAUTION: Use Personal Protective Equipment (PPE). Wear appropriate clothing as well as eye protection when operating power tools.



Figure 6: Aligning the Template

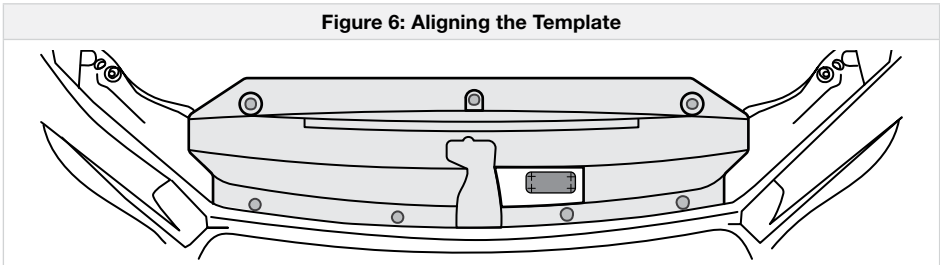

FITTING THE RADIATOR COVER PANEL

Check the inspection hole for alignment with the Battery Charger's front panel and if required, remove the cover panel from the vehicle to trim excess plastic. Re-fit the radiator cover panel to the vehicle with the clips removed during panel removal. These clips are secured when the centres are flush with the outer edge of the clip.

Figure 7: Fitting Clips to the Cover Panel

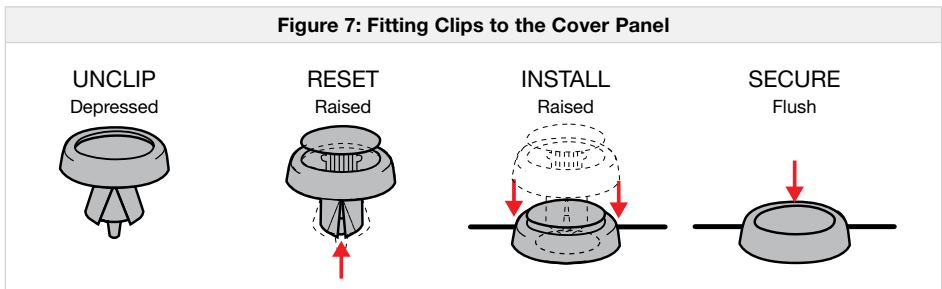

COMPLETED INSTALLATION

Once the radiator cover panel is fitted back to the vehicle, the installation is complete.

Figure 8: Completed Installation

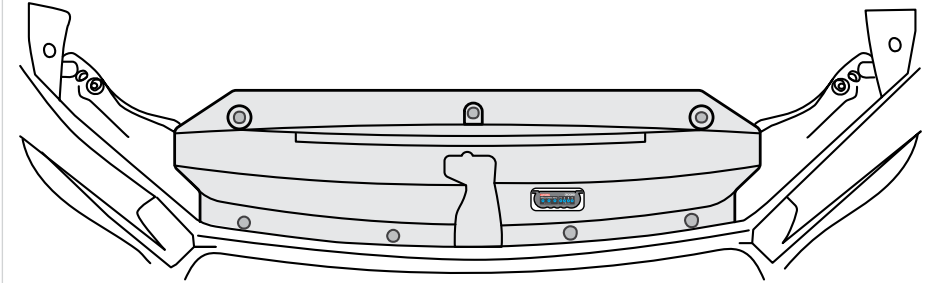

MAINTENANCE

⚠ CAUTION: Ensure the area around the Battery Charger is clean and clear of debris. Any debris not removed will impair the performance of the unit and may cause a fire hazard.

NOTE: Regularly check your vehicle to avoid potential damage to the Battery Charger, your vehicle and batteries (both auxiliary and starter).

WARRANTY

LIMITED WARRANTY

For full warranty terms and conditions, visit the Warranty page of the REDARC website.

www.redarcelectronics.com/warranty

Australia, New Zealand & Europe

REDARC Electronics Pty Ltd
23 Brodie Road (North),
Lonsdale SA 5160
Australia

Australia +61 8 8322 4848
New Zealand +64 9 222 1024
UK & Europe +44 (0)20 3930 8109

North America

REDARC Corporation
c/o Shalco, Inc.
308 Component Dr.
Smithfield, NC 27577
USA

USA +1 (704) 247-5150
Canada +1 (604) 260-5512
Mexico +52 (558) 526-2898

Tech Support

1300 REDARC (1300-733-272)

Australia

+61 8 8322 4848

New Zealand

+64 9 222 1024

UK & Europe

+44 (0)20 3930 8109

USA

+1 (704) 247-5150

Canada

+1 (604) 260-5512

Mexico

+52 (558) 526-2898

redarcelectronics.com

THE POWER OF

REDARC®